

AQUAS[®] INSTRUCTION GUIDE AND USER MANUAL

INSTANTANEOUS ELECTRIC WATER HEATER - AQUAS SPA

By

AQUABELLA SHOWER CO.,LTD.



AQUAS SPA 1 OUTLET
9.5 kW.



AQUAS SPA 2 OUTLET FLEX
9.5 kW.

IMPORTANT !

This Step-by-Step guide should be given to the customer
after installation and demonstration

These instructions contain all the necessary fitting and operating instructions for your electric shower. Care taken during the installation will provide a long, trouble free life from your shower.

PLEASE READ THIS IMPORTANT SAFETY INFORMATION



WARNING: DO NOT operate shower if frozen, or suspected of being frozen. It must thaw out before using.



DO NOT operate the unit if the shower-head or spray hose becomes damaged.



DO NOT restrict flow out of shower by placing shower-head in direct contact with your body.



DO NOT operate the shower if water ceases to flow during use or if water has entered inside the unit because of an incorrectly fitted cover.



WARNING: If restarting the shower immediately after stopping, be aware that a slug of hot water will be expelled for the first few seconds.

PLEASE READ THIS IMPORTANT SAFETY INFORMATION (CONT.)

IMPORTANT: This appliance is not intended for use by persons (Including children) with reduced physical, sensory or mental capabilities, or lack of experience and knowledge, unless they have been given supervision or instruction concerning use of the appliance by a person responsible for their safety. Children should be supervised to ensure that they do not play with the appliance.

IMPORTANT: To comply with water regulations, building regulations or any specific local water company regulations and should be in accordance with BS EN 806. A double check valve must be fitted with all flexible shower accessories where it is possible that the showerhead may come into contact with used water i.e. In the bath or shower tray.

IMPORTANT: Before turning on the water supply to the shower unit the water supply pipe should be flushed out to remove debris. After flushing the pipework ensure that the shower unit is positioned squarely on the wall and tighten the screws. Tighten all plumbing connections and check the pipework for leaks.

IMPORTANT: Ensure that the terminal block screws are fully tightened and that no cable insulation is trapped under screws. Ensure the cable clamp is used to secure the cable. The earth continuity conductor of the electrical installation must be effectively connected to all exposed metal parts of other appliances and services in the room in which the shower unit is installed.

CAUTION: Check there are no hidden cables or pipes before drilling holes for wall plugs. Exercise great care when using power tools near water. The use of a residual current device (RCD) is recommended.

IMPORTANT: Turn the Temperature control knob anticlockwise until the valve is fully open before switching on the unit.

This will ensure a fast fill up of the unit when the shower is first switched on.

IMPORTANT: The shower unit must be full of water before heat settings are used.

WARNING: If re-starting the shower immediately after stopping, be aware that a slug of hot water will be expelled for the first few seconds.

ATTENTION: Do not operate the shower unit if the showerhead or hose becomes damaged. The shower is designed and approved to EN-60335 with the showerhead provided. Under no circumstances must any showerhead that is not approved by the manufacturer be used with this product.

IMPORTANT

- Shower Installation must be carried out by a suitably qualified person and conform with IEE Regulations and comply with water regulations, building regulations or any specific local water company regulations and should be in accordance with BS EN 806.
- This shower unit is designed to be connected to a direct cold water mains supply without draw offs that also feed other appliances or taps as this will impair performance. Aquas Electric showers are not compatible or suitable for installation using a Gravity Fed system.
- To make sure of activating the heating elements, the shower must be connected to a mains water supply with a minimum running pressure of 100kPa (15 lb/sq in) - (1 Bar) at a minimum flow rate of 8 litres per minute. The maximum static pressure must be no greater than 500kPa (75 lb/sq in)-(5.0 Bar).
- Your Aquas Spa electric shower should always be mounted on the finished wall surface (usually tiled). Under no circumstances must you tile up to or seal around the unit as this may prevent air circulation and any possible condensation escaping.
- The shower unit must not be fitted where it may be exposed to frost, for example in an outdoor area. The shower must not be used if suspected of being frozen. Frost damage is not covered by the guarantee.
- All plumbing connections must be completed before making the electrical connections.
- Always switch off at the isolating switch when not in use.

GENERAL ADVICE TO SHOWER UNIT USERS

The flow rate of water passing through the shower unit determines the water temperature. The lower the flow the warmer the water, the higher the flow the cooler the water.

The temperature produced by the shower unit will vary between seasons on any one setting of the temperature control. This is due to variance in the temperature of the water supply, which becomes cooler in winter than summer.

The stabiliser valve maintains an almost constant shower temperature during mains water pressure changes.

If changes in temperature are experienced in normal use, it is likely to be caused by water pressure falling below the minimum level. Falls in water pressure may be due to water being drawn off at other points within the building.

The showerhead and filter must be cleaned regularly to remove scale and debris. If the water becomes hot and you are unable to obtain cooler water, check the showerhead, Handshower, shower hose, and filter for blockage.

GENERAL LAYOUT OF A SHOWER INSTALLATION

A TYPICAL INSTANTANEOUS ELECTRIC SHOWER INSTALLATION

Plan your own installation carefully. Check on the nearest and most readily accessible rising mains water supply, this may be beneath the bath or in the loft, where it feeds the cold water storage tank. Use only the cold rising water main supply.

Do not connect the shower unit to the outlet from the cold water tank.

Avoid connecting the shower unit, if possible, where it will be affected by water drawn off by other appliances, e.g. From the mains feed to the W.C. This may cause a drop in pressure too low for the shower unit to work correctly.

An isolating valve must be fitted to comply with water regulations and for servicing purposes.

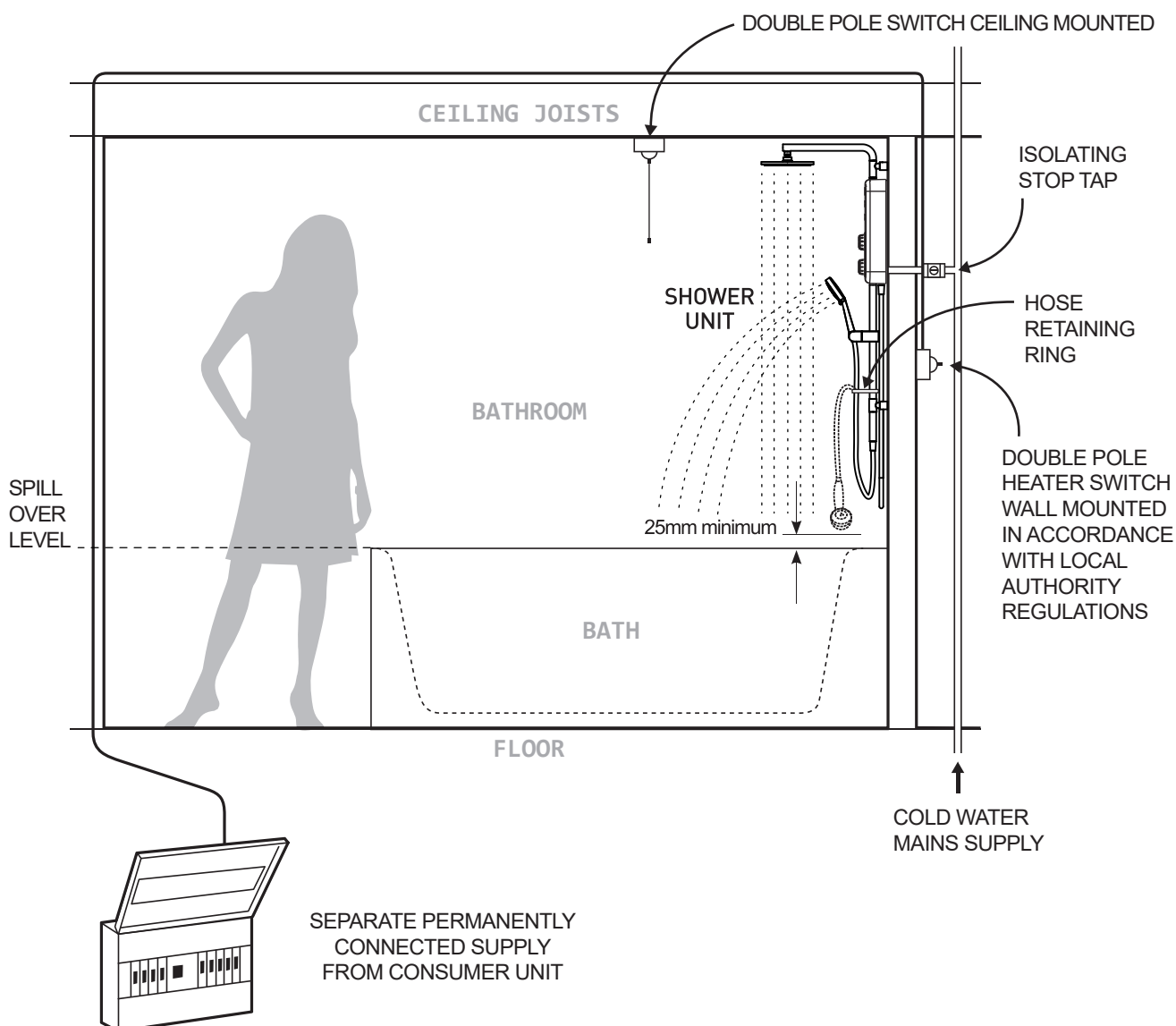

⚠ IMPORTANT ⚠

This appliance is not intended for use by persons (including children) with reduced physical, sensory or mental capabilities, or lack of experience and knowledge, unless they have been given supervision or instruction concerning use of the appliance by a person responsible for their safety. Children should be supervised to ensure that they do not play with the appliance.

RECOMMENDED INSTALLATION DIMENSIONS FOR ALL MODELS

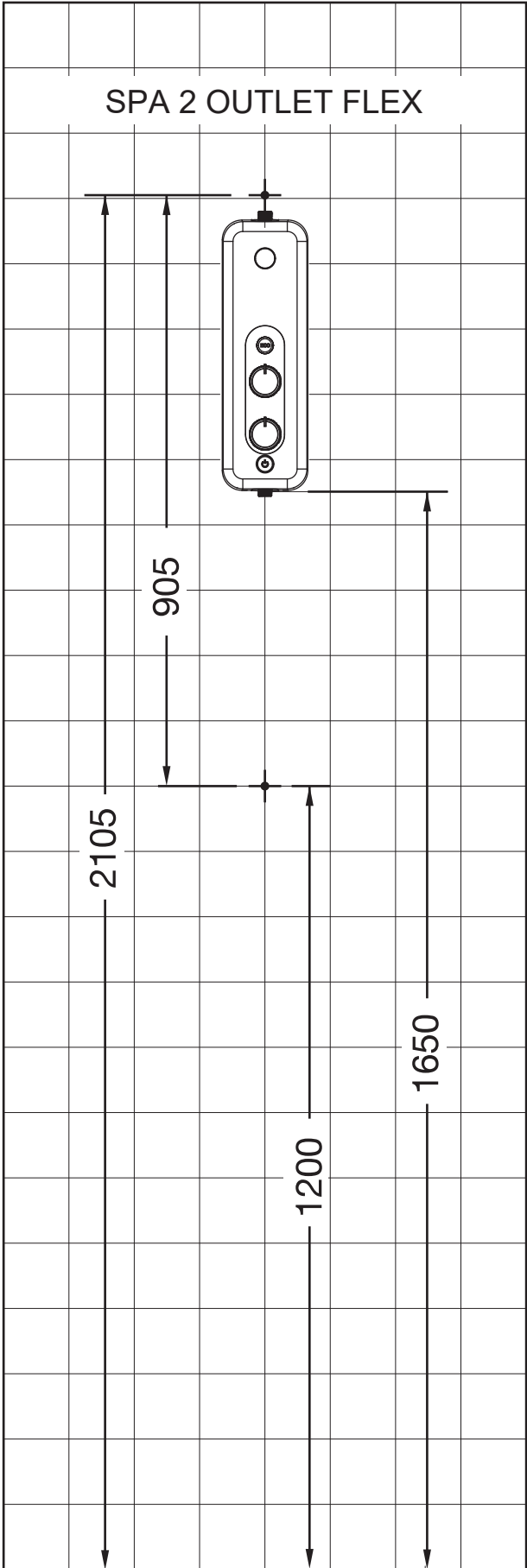
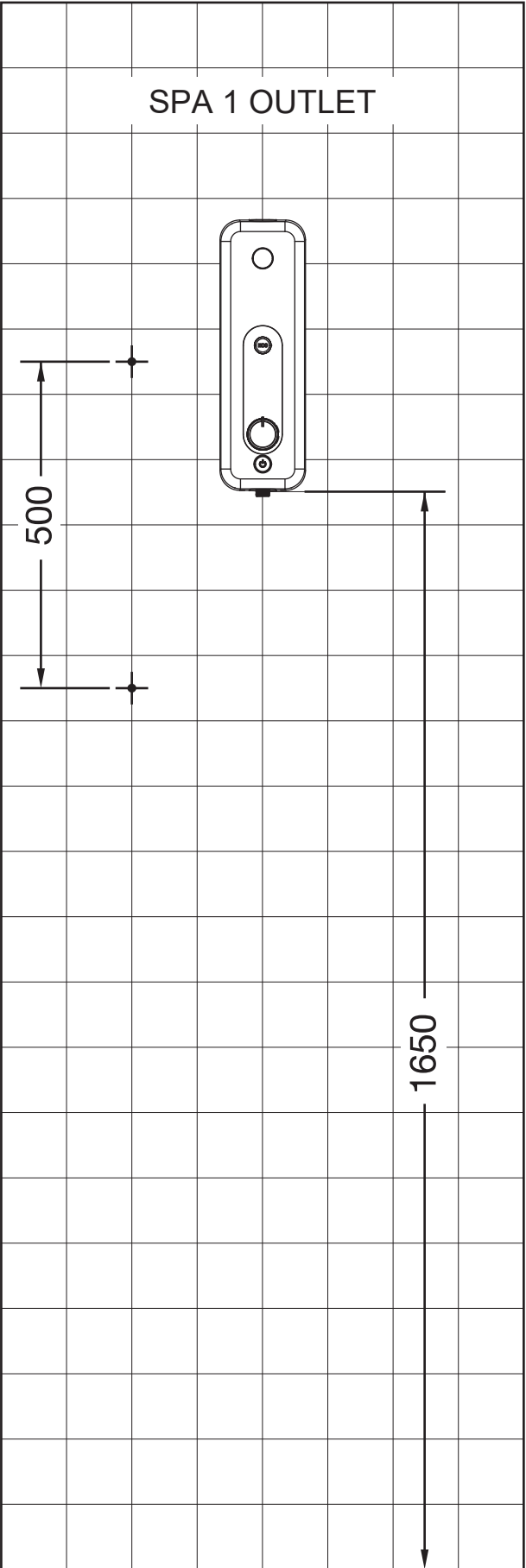

AQUAS SPA 9.5 KW WATER HEATERS

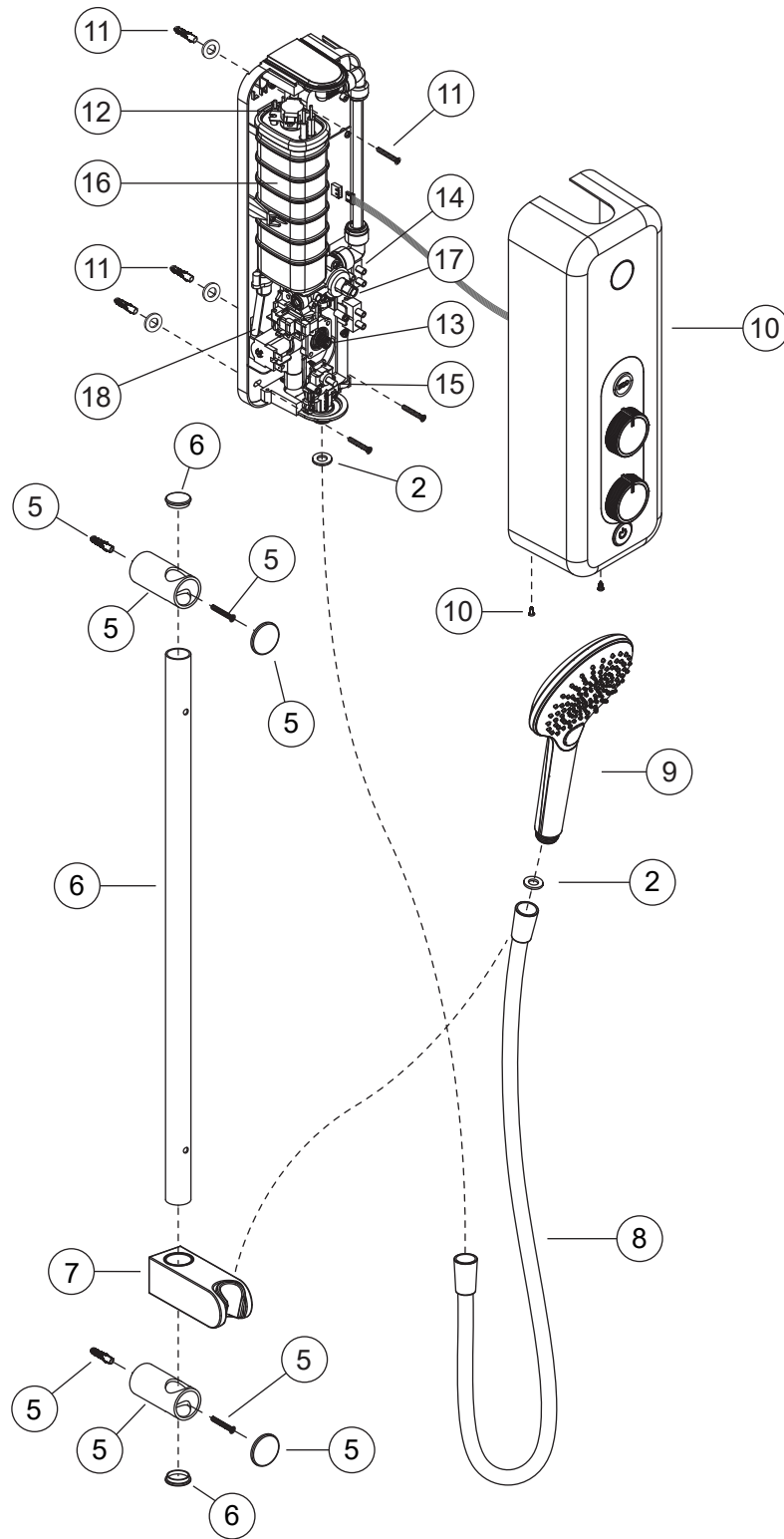

AQUAS SPA FLEX 9.5 KW WATER HEATERS

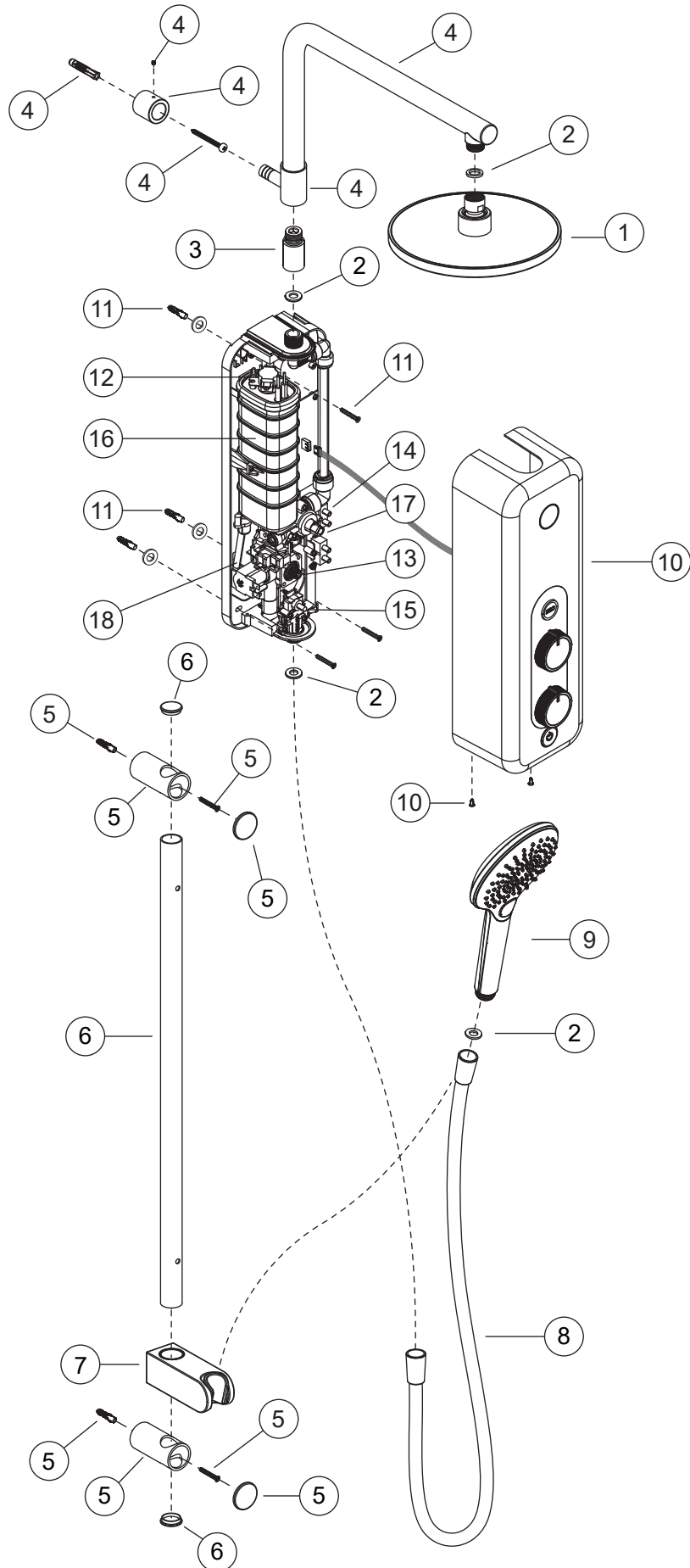

ASSEMBLY OF UPPER SHOWERING COMPONENTS

STEP 1

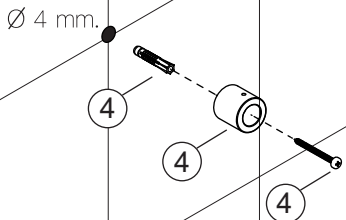

STEP 2

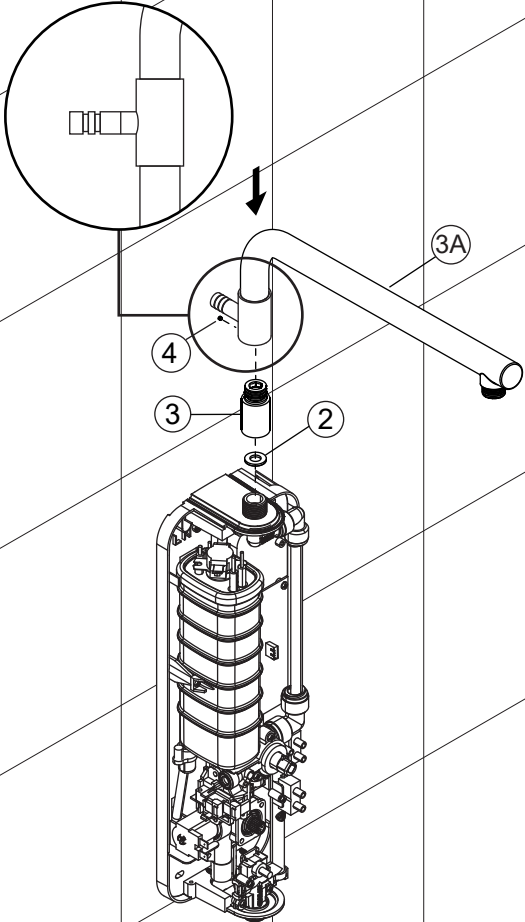

ASSEMBLY OF LOWER SHOWERING COMPONENTS

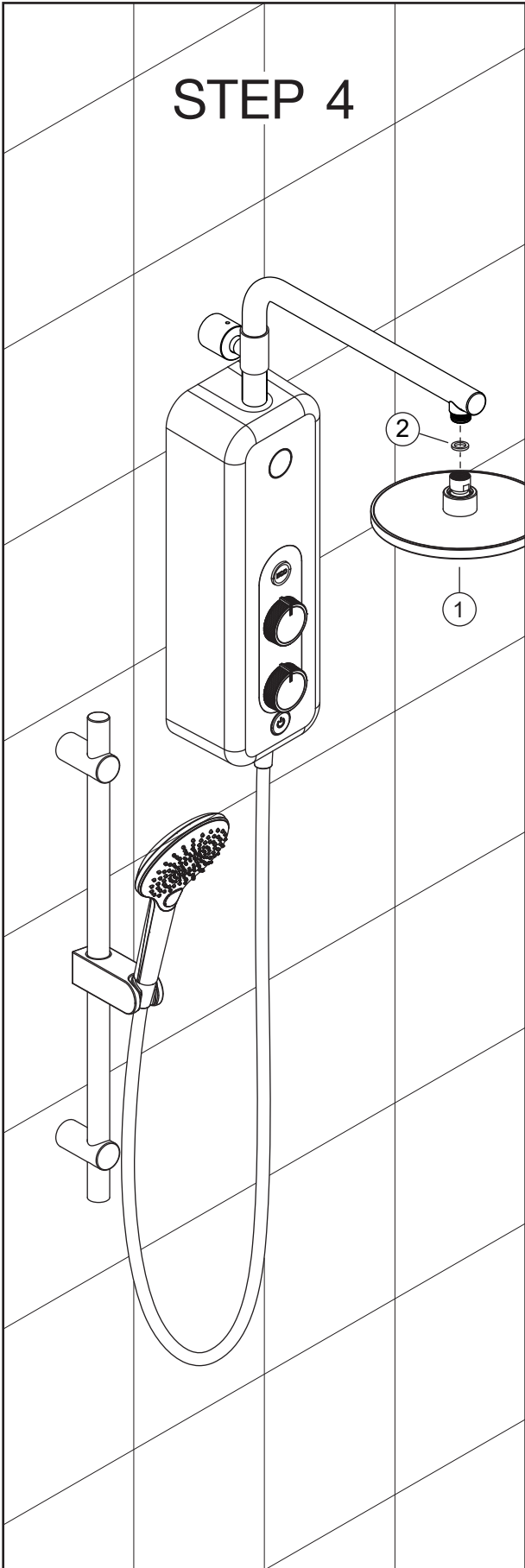
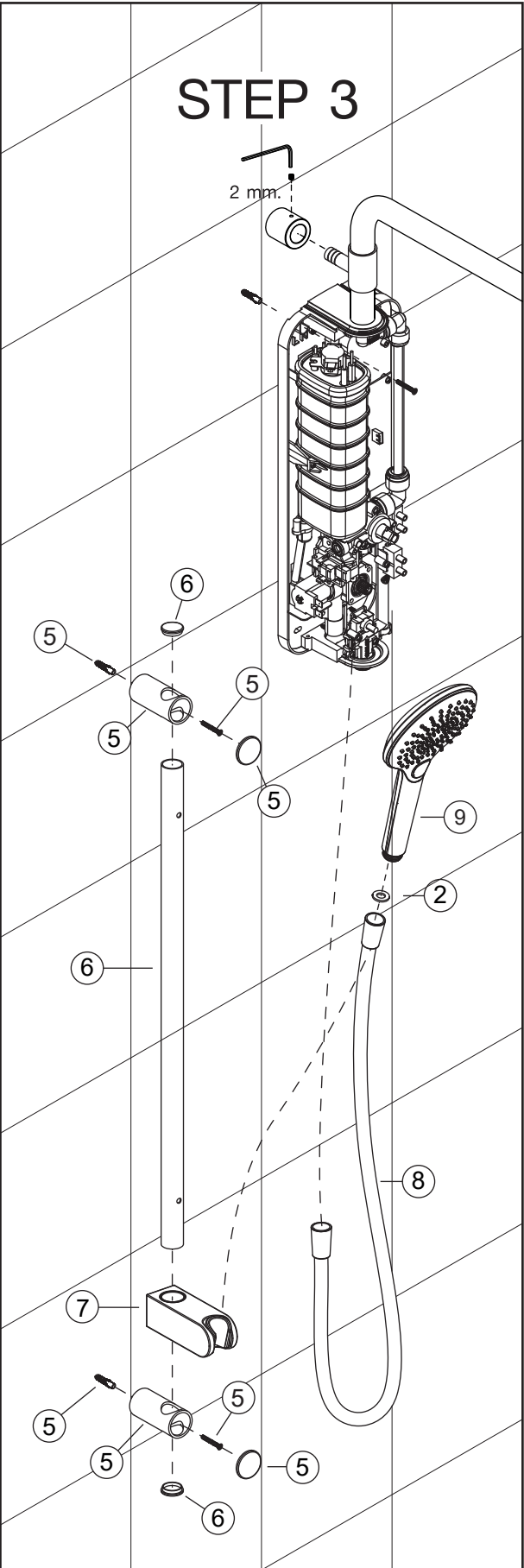

PLUMBING CONNECTIONS

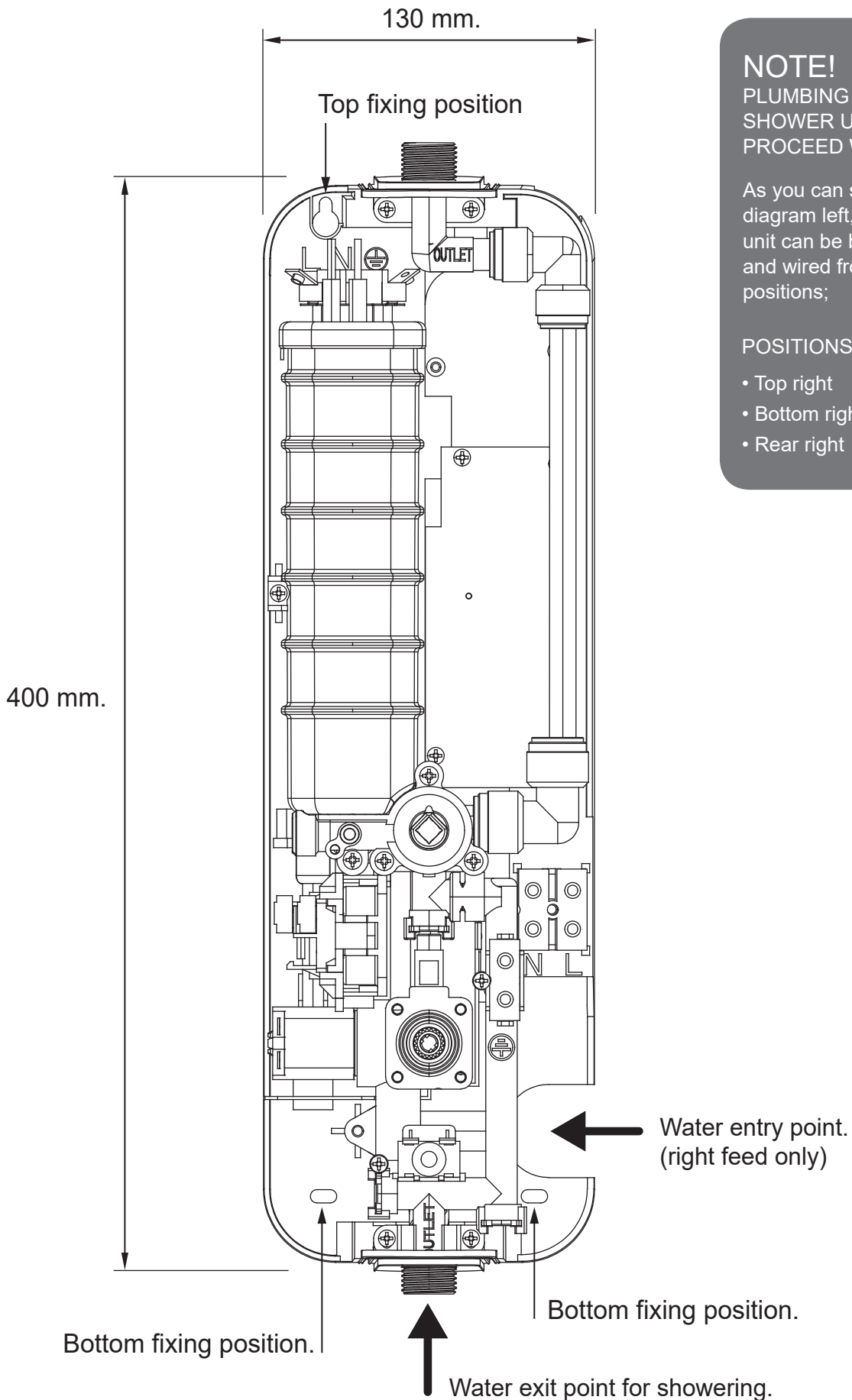

NOTE!

PLUMBING THE SHOWER UNIT MUST PROCEED WIRING!

As you can see from the diagram left, The shower unit can be both plumbed and wired from 3 different positions;

POSITIONS:

- Top right
- Bottom right
- Rear right

PLUMBING CONNECTIONS

Turn off the water supply at the isolating stop tap.

Having determined the direction of the inlet water supply: Top (falling), Bottom (rising), or Back inlets.

It is necessary to remove the appropriate plastic cross section from the back plate, before commencing with the installation.

Connect the mains water supply to the inlet of the shower unit using a 15mm. copper, stainless or plastic pipe with a 15mm. compression elbow or 15mm. push-fit elbow.

Do not use excessive force when making the connection to the unit.

PLUMBING SETTING

The shower unit is supplied for right hand installation.

When leak testing the installation you must ensure there are no leaks from this area.

IMPORTANT

To comply with water regulations, building regulations or any specific local water company regulations and should be in accordance with BS EN 806. A double check valve must be fitted with all flexible shower accessories where it is possible that the showerhead may come into contact with used water i.e. In the bath or shower tray.

IMPORTANT

Before turning on the water supply to the shower unit the water supply pipe should be flushed out to remove debris. After flushing the pipework ensure that the shower unit is positioned squarely on the wall and tighten the screws. Tighten all plumbing connections and check the pipework for leaks.

ELECTRICAL CONNECTIONS

Your Aquas Reva electric shower is provided with both Left and Right electrical connections to ease installation particularly when replacing an existing unit

NOTE: ONLY ONE SET OF ELECTRICAL CONNECTIONS IS NECESSARY

ELECTRICAL SPECIFICATIONS

Nominal Power rating at 240V
9.5kW - (45A MCB rating)

The shower unit must be permanently connected to the electricity supply, direct from the consumer unit via a double pole linked switch with a minimum contact gap of 3mm. The switch must be readily accessible and clearly identifiable and out of reach of a person using a fixed bath or shower tray, unless the switch is cord operated. The wiring must be connected to the switch without the use of a plug or socket outlet.

The cable size required is determined by the kW rating of the shower and the distance between the shower and the consumer unit. The table below will help you choose the correct cable for your installation, but it will depend upon the precise circumstances of the installation. If you are in any doubt consult an electrician.

The incoming cable should be hidden.

KW RATING	NOMINAL AT 240V	MIN RATING OF ISOLATING SWITCH	FUSE RATING	MAX CABLE RUN	
				6mm	10mm
9.5	39.58amps	45amps	45amps	10m	32m

The diagram below shows the route of the cable into the shower unit for connection to the terminal blocks, connect as follows:

Earth cable to terminal marked 

Neutral cable to terminal marked N

Live cable to terminal marked L

EXAMPLE - RIGHT SIDE ELECTRICAL CONNECTIONS

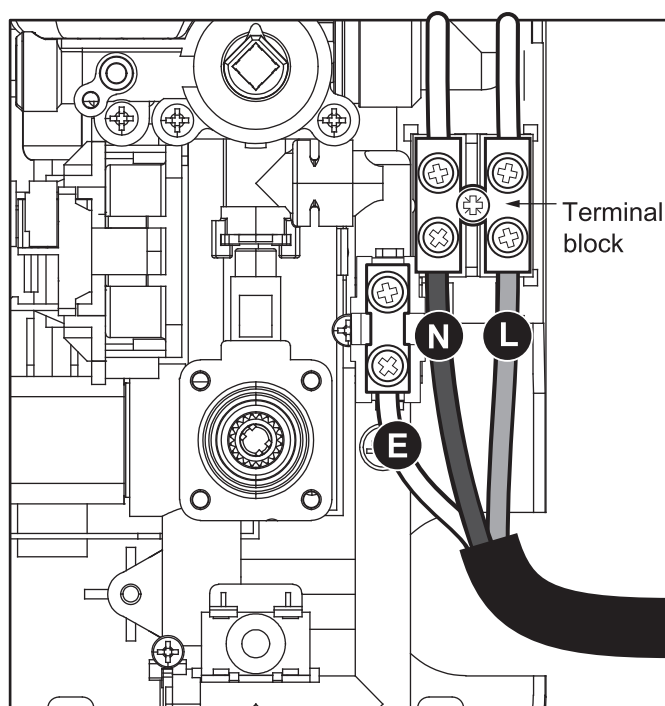

IMPORTANT

Ensure that the terminal block screws are fully tightened and that no cable insulation is trapped under screws. Ensure the cable clamp is used to secure the cable. The earth continuity conductor of the electrical installation must be effectively connected to all exposed metal parts of other appliances and services in the room in which the shower unit is installed to confirm.

ELECTRICAL WIRING

IMPORTANT: When connecting the cable fully tighten the terminal block screws and make sure that no cable insulation is trapped under the screws. Loose connections can result in cable overheating.

NOTE: The elements on UK models are to 240V specification and will give a lower kW rating if the voltage supply is below 240V.

NOTE: The supply cable earth conductor must be sleeved. The outer sheath of the supply cable must be stripped back to the minimum.

The use of connections within the unit or other points in the shower circuit to supply power to other equipment i.e. extractor fans, pumps etc. will invalidate the guarantee.

DO NOT switch on the electricity supply until the shower cover has been fitted.

FITTING THE FRONT COVER INTO POSITION

When fitting the cover, it is important to align the diverter spindle and volume control spindle inside the heater.

DIVERTOR HANDLE

Make sure that the Divertor spindle and the raised button on the diverter handle are in the 12 O'clock position before fitting the cover.

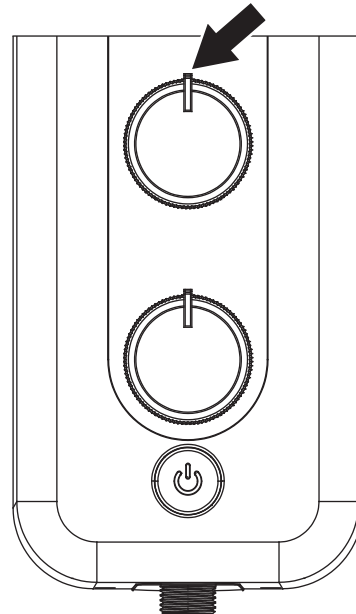
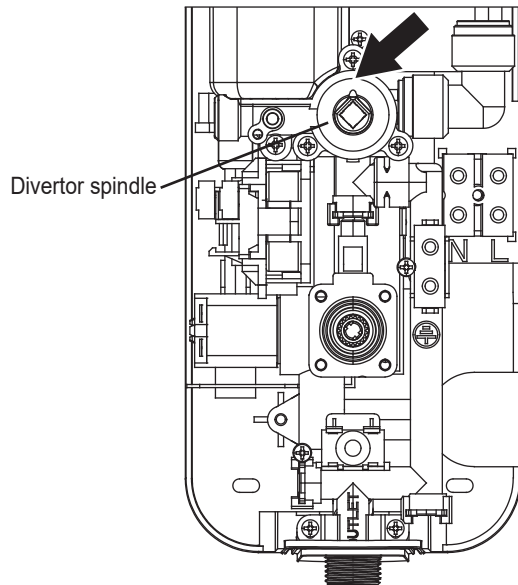

VOLUME CONTROL HANDLE

Turn the stabilizer valve spindle and volume handle fully clockwise until resistance is felt.

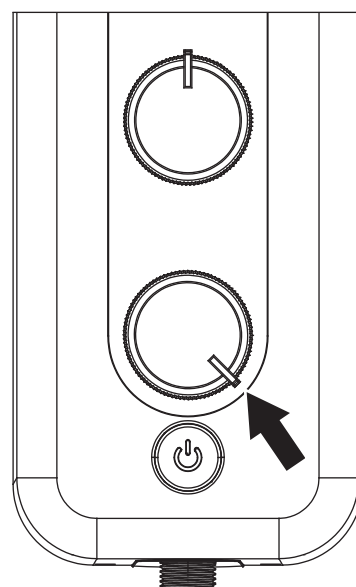
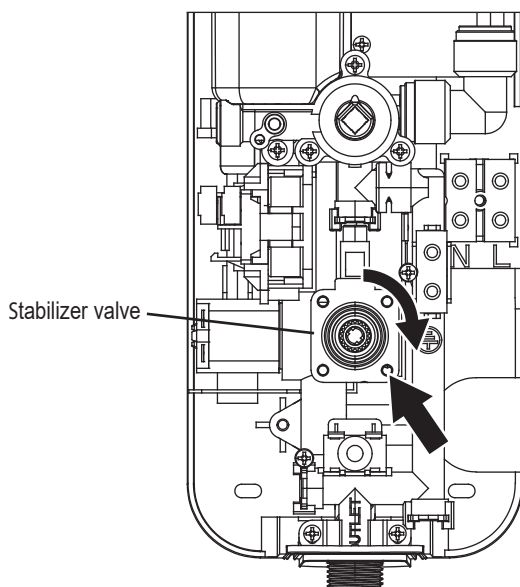

Fit cover into position and re-fit cover fixation screws.

NOTE - Before fitting the cover, ensure that the 2 electrical wires are fitted correctly to the PC board inside the electric shower.

COMMISSIONING THE SHOWER HEATER

IMPORTANT NOTE FOR THE INSTALLER

1. Before installation, rotate the volume control handle clockwise until resistance is felt. Connect the water and electricity supply.

2. Turn on the water and electricity, before fitting the front cover. Push the on/off button, to check water flow and if there is any leakage inside the heater or at any shower connection.

3. Before fitting the cover, turn off the electricity supply. Remove this square plastic part in the picture. Fit the front cover. Turn on the water and electricity again, and the product should now work normally.

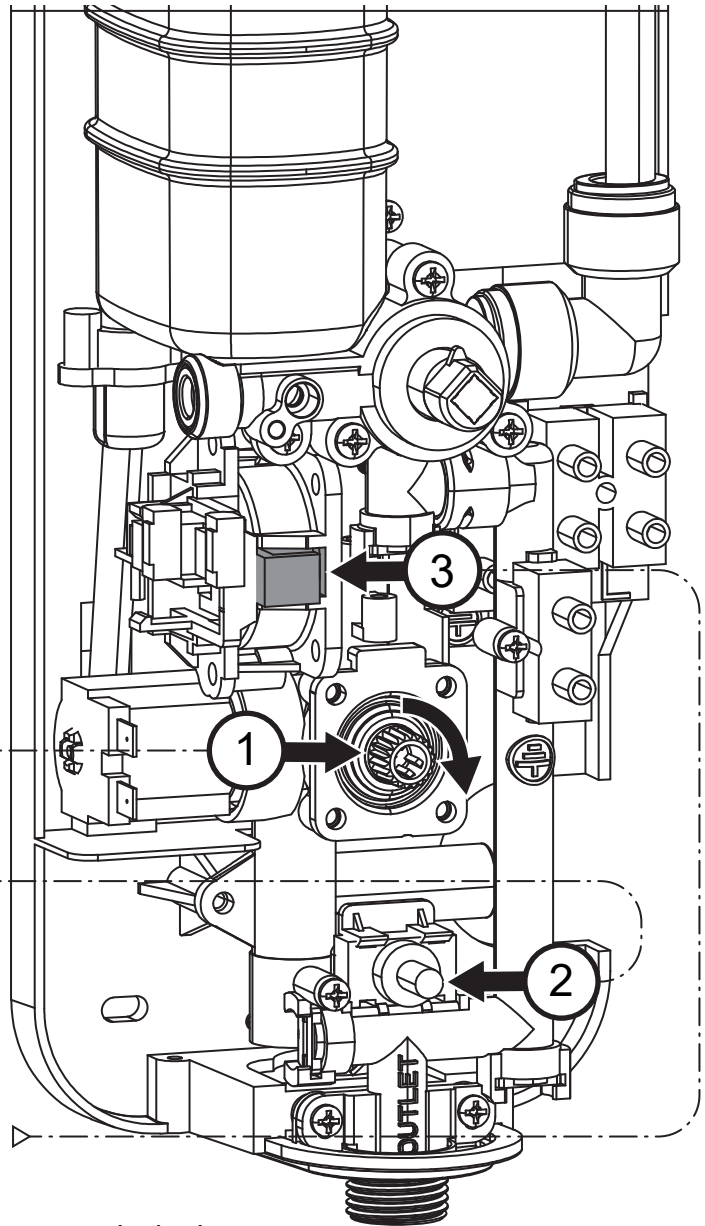

WARNINGfailure to remove that part after commissioning will result in NO hot water reaching the shower.

⚠ IMPORTANT ⚠

Turn the Temperature control knob anticlockwise until the valve is fully open before switching on the unit. This will ensure a fast fill up of the unit when the shower is first switched on.

⚠ IMPORTANT ⚠

The shower unit must be full of water before heat settings are used.

OPERATING THE SHOWER

1. Switch on electrical supply - pull cord or wall mounted switch.
2. Press the ON / Off Button to start the flow of water.
3. Turn the diverter handle to select the showering function you require
Left for Hand-shower & Right for Overhead.
4. When turning the Volume Control Handle, this will change the output temperature of the water.
5. In the winter months, the heater should be operated at full power (9.5 KW) to ensure an adequate amount of hot water
In the summer months, the ECO button can be activated which will reduce the KW output down to 5.0 KW.
6. To turn off the shower unit, press the ON / OFF button.

Temperature and Power Setting Indicator
In Winter Mode :
Both Half Circles Light up
In Summer Mode :
Only the bottom Half Circle Lights up

Winter 9.5 kw and
Summer 5.0 kw Setting
Full power /
Eco power button

Divertor handle
Hand-shower
Or overhead function

Volume Control Handle

On / Off Button

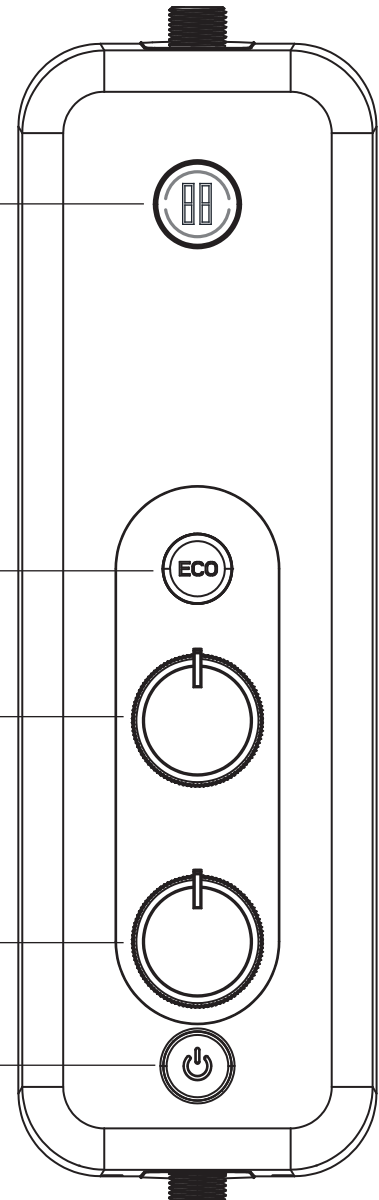

IMPORTANT NOTES

The Higher the flow the temperature will decrease.

The Lower the flow the temperature will increase.

It is recommended that you start the shower with the volume handle in the fully anti clockwise / cold position as this will provide maximum flow

If a higher outlet temperature is required, Rotate the volume handle in a clockwise direction.

TROUBLESHOOTING

Symptom	Likely causes	Action / remedy
Heater shows LP in temperature display	Inlet pressure too low	A) Check inlet pressure. A minimum 1.0 Bar Dynamic flow pressure is required
		B) increase inlet pressure
		C) if old installation , outlet flow may be restricted . Clean filter , outlet holes in over-head , hand-shower , and filter in shower hose
Heater shows E1 is temperature display	Flow sensor cable not working	A) Replace Flow Sensor cable
	P C Board Failure	B) Replace PC Board
Heater shows OT in Temperature display	Outflow restricted causing temperature of hot water in the tank to exceed safety temperature	A) Check for blockage - clean inlet filter
	Reduced flow / temperature rising to fast	B) Turn Flow handle anticlockwise to increase flow and lower outlet temperature
	Shower components may be blocked due to a build up of lime-scale	C) if old installation , outlet flow may be restricted, clean outlet holes in overhead , hand-shower , and filter in shower hose
Heater fluctuates between hot and cold / default to a lower power setting	Temperature ring too fast - if temperature reaches 49 degrees +/- 2 , it will trip the Thermal cut off safety device	DO NOT Change shower setting without adjusting the flow handle . Turn Flow handle anticlockwise to increase flow and lower outlet temperature
Heater wont turn on / stopped working	Check for leaks - Small PC Board inside cover (Lower position) has become faulty	Replace small PC Board inside cover
Heater display malfunctioning	Check for leaks - larger PC Board inside cover (higher position) has become faulty	Replace larger P C Board inside cover
Water from pressure relief outlet - PRD activated.	Obstruction causing back pressure	Replace membrane washer behind the pressure relief tube (located at the base of the tank. If old installation , outlet flow may be restricted, clean outlet holes in overhead , hand-shower , and filter in shower hose

SHOWERHEAD CLEANING INSTRUCTIONS

The showerhead should be cleaned periodically to remove limescale or debris which will reduce the performance of the shower. The frequency of cleaning will vary according to local water quality.

PERIODICAL MAINTENANCE

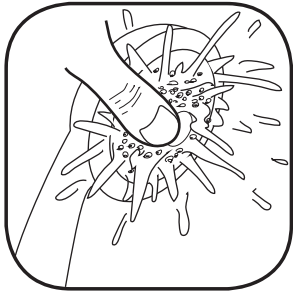

1. To break away scale deposit on a daily basis simply rub your thumb over the surface whilst the shower is running.

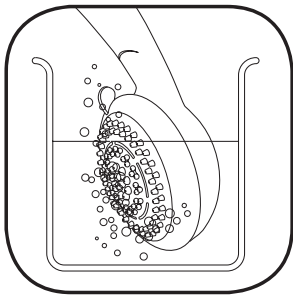

2. If scale deposits are stubborn, Soak the shower-head or hand-shower in a proprietary Limescale remover and rinse thoroughly before use.

**Register your product
for full warranty!**

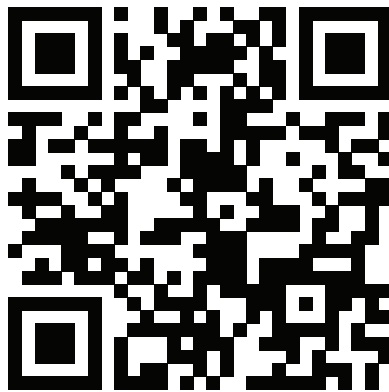

[http://aquasshower.co.uk/
en/info/service-registration](http://aquasshower.co.uk/en/info/service-registration)

Your AQUAS Branded heaters are supplied by Aquabella Shower Co.,Ltd. in Thailand. For information or service assistance , please contact the installer or the local UK distributor from where the heater was purchased.